



# Modell 1550

Ausführung:

Seriennummer:

Code: **22906**

03/05/2010

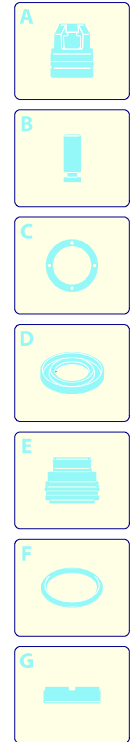
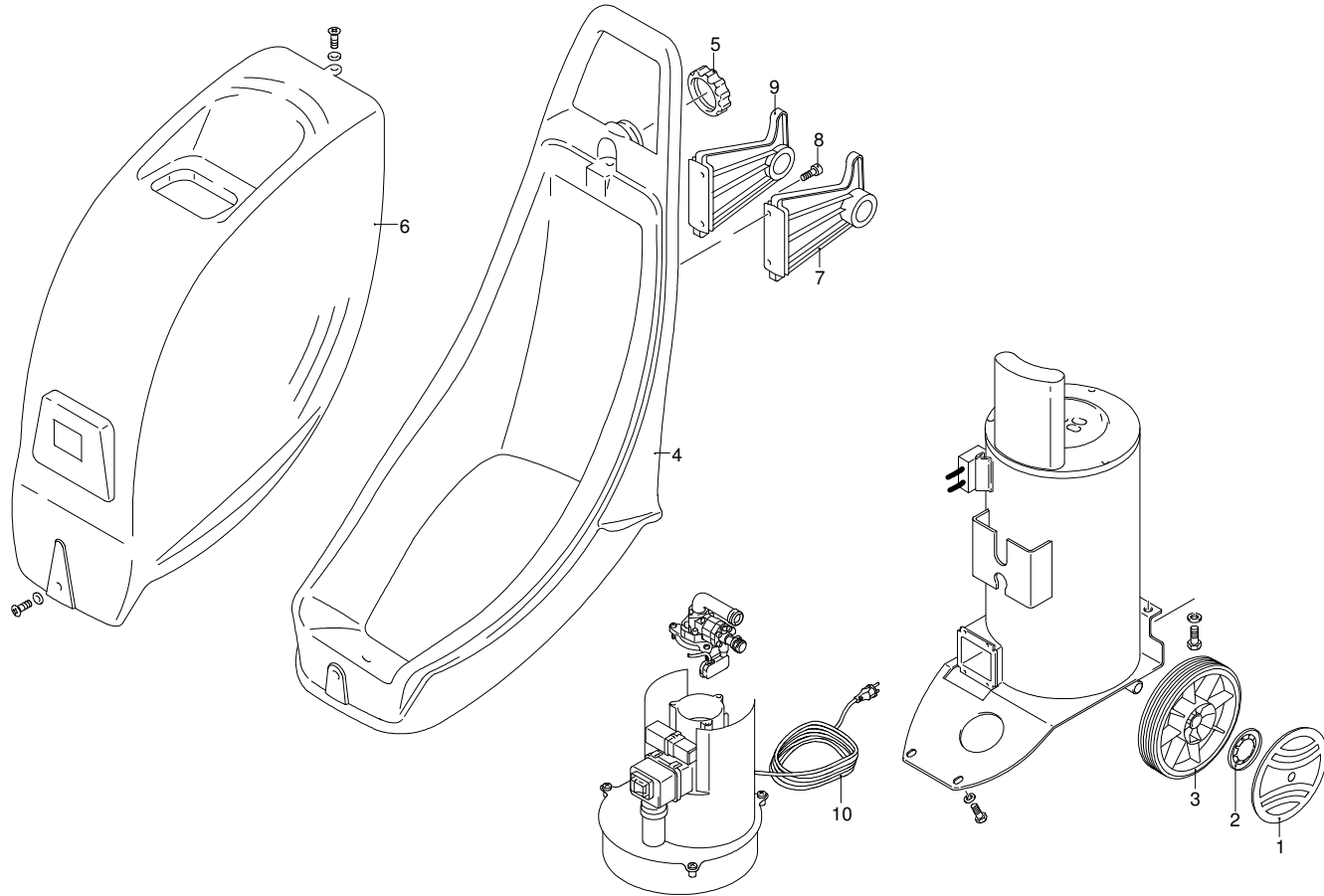
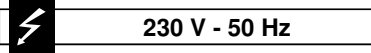

Gültigkeit	Pos.	Code	Bezeichnung	Menge
	1	3160260	Grau Schutzeinrichtung	2
	1	50897	Blau Schutzeinrichtung	2
	2	3162010	Unterlegscheibe	1
	3	3160240	Rad	1
	4	3162340	Tank	1
	5	50933	Verschluss	1
	6	3162360	Dunkelblaue Haube	1
	7	3160010	Bügel	1
	8	1681080	Schraube	4
	9	3160020	Bügel	1
	10	1272600	Kabel	1

UN\_CE\_0400-CW



# Modell 1550

Ausführung:

Seriennummer:

Code: **22906**

03/05/2010

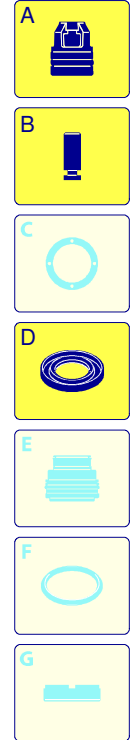
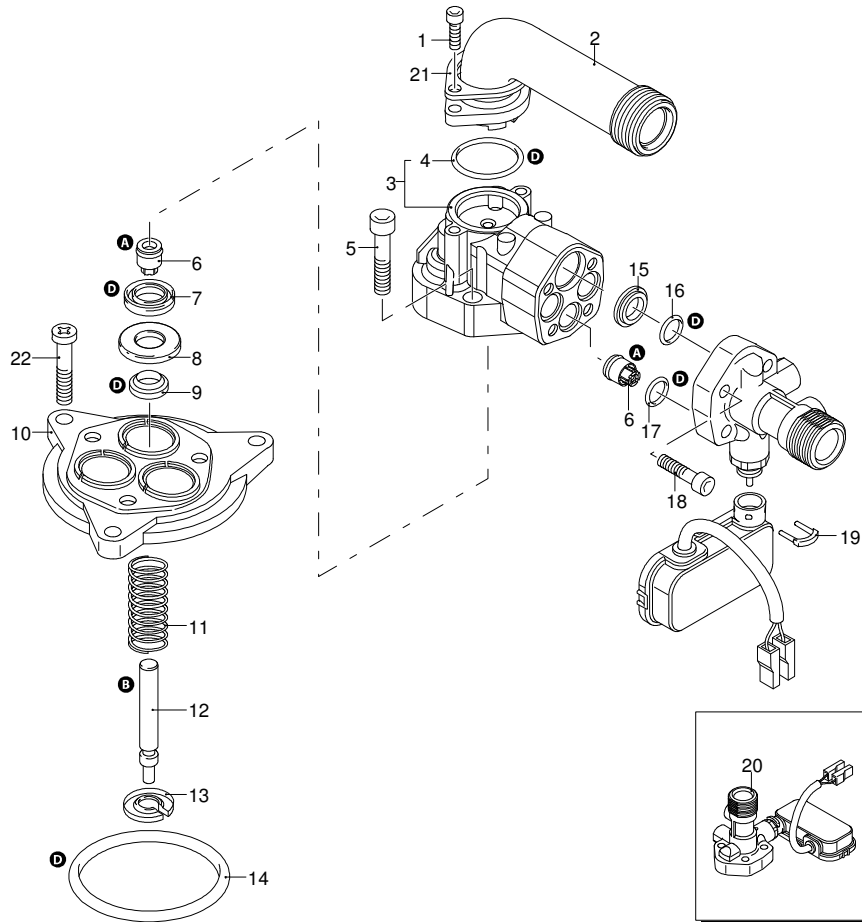
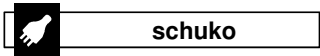
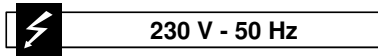

Gültigkeit	Pos.	Code	Bezeichnung	Menge
	1	2101000	Schraube	2
	2	2100630	Verbindungsstück	1
	3	2122	Kopf-O-Ring-Dichtung	1
	4	550350	O-Ring-Dichtung	1
	5	850850	Schraube	3
	6	2109050	Ventil	6
	7	2200141	Wasserdichtung	3
	8	2020041	Ring	3
	9	1683500	Öldichtung	1
	10	2100030	Kolbenführung	3
	11	2561120	Feder	3
	12	2100130	Kolben	3
	13	2020140	Teller	1
	14	850840	O-Ring-Dichtung	1
	15	2560480	Buchse	1
	16	394280	O-Ring-Dichtung	1
	17	880840	O-Ring-Dichtung	3
	18	1260760	Schraube	4
	19	2021960	Klemme	1
	20	2264	Vormontage Verbindungsstück	1
	21	2101450	Flansch	1
	22	2100980	Schraube	3
	23	42434	Vormontage Pumpe	1
	A	2574	Satz Ventile	1
	B	2508	Satz Kolben	1
	D	42421	Satz Dichtungen	1

UN\_CE\_0401-CW



# Modell 1550

Ausführung:

Seriennummer:

Code: **22906**

03/05/2010

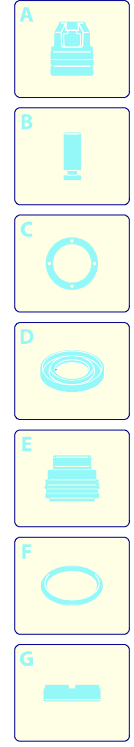
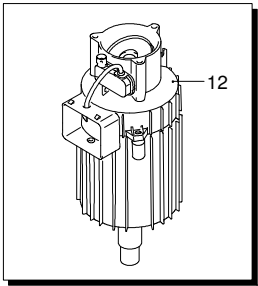
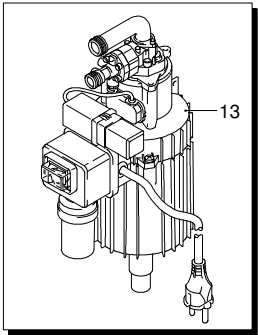
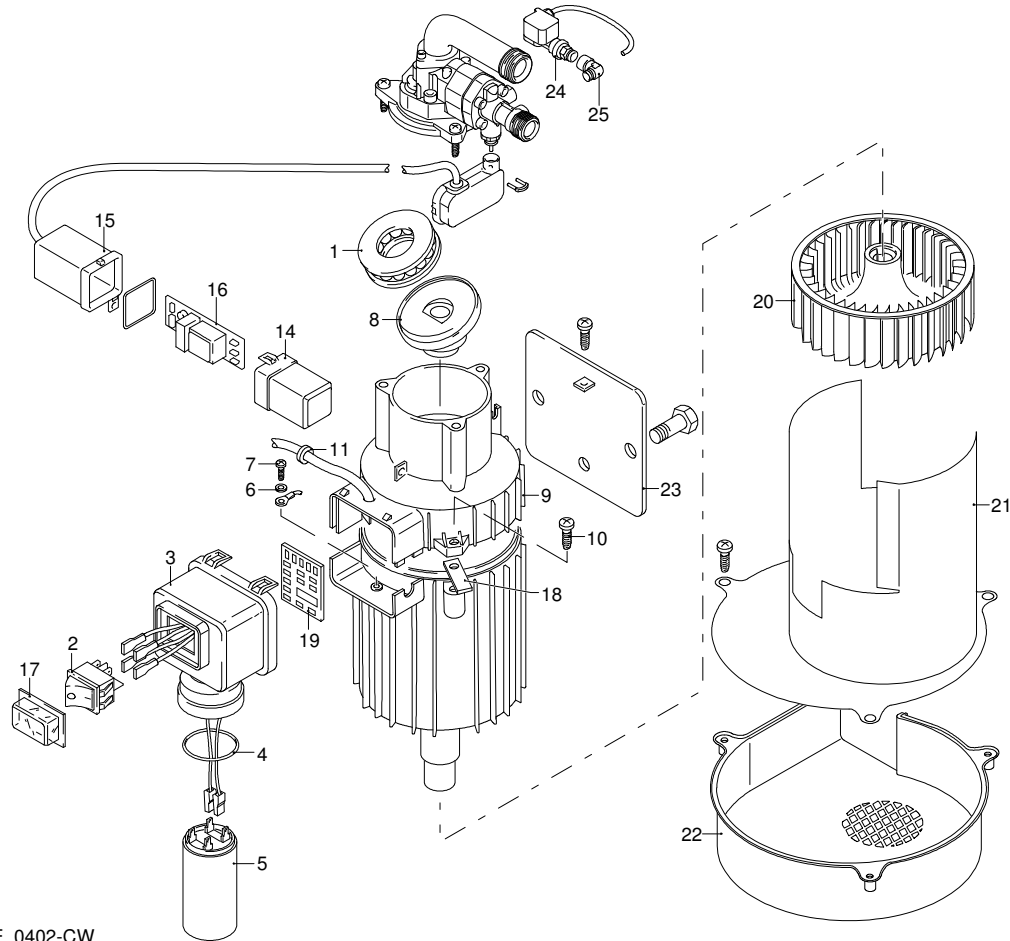
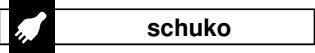
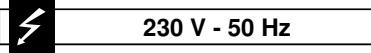

Gültigkeit	Pos.	Code	Bezeichnung	Menge
	1	2021570	Lager	1
	2	2102070	Schalter	1
	3	2100060	Kasten	1
	4	390201	O-Ring-Dichtung	1
	5	1682640	Kondensator	1
	6	1262400	Unterlegscheibe	1
	7	2020570	Schraube	1
	8	2102170	Teller	1
	9	2109282	Vormontage Hauptteil Pumpe	1
	10	2100980	Schraube	3
	11	1462900	Kabeldurchführung	5
	12	44253	Motor	1
	13	22946	Vormontage Elektropumpe	1
	14	2102060	Kasten	1
	15	2102050	Kasten	1
	16	3162790	Karte	1
	17	2102600	Schutzkasten	1
	18	2440160	Platte	1
	19	3163550	Karte	1
	20	3162160	Lüfter	1
	21	3162170	Deckel	1
	22	3162150	Gehäuse	1
	23	3162250	Platte	1
	24	3162890	Druckmesser	1
	25	3161220	Verbindungsstück	1



# Modell 1550

Ausführung:

Seriennummer:

Code: **22906**

03/05/2010

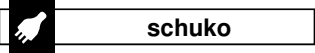
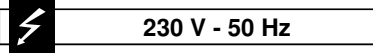

Gültigkeit	Pos.	Code	Bezeichnung	Menge
	1	2180740	Nutmutter	1
	2	3160150	Verbindungsstück	1
	3	3160140	Rohr	1
	4	3160430	Verbindungsstück	1
	5	3162140	Verbindungsstück	1
	6	3160540	Ventil	1
	7	3162230	Rohr	1
	8	3162300	Dichtung	1
	9	3162310	Verbindungsstück	1
	10	3160490	Nutmutter	1
	11	1340260	Filter	1
	12	1461470	Verbindungsstück	1
	13	1140690	Schelle	2

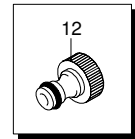
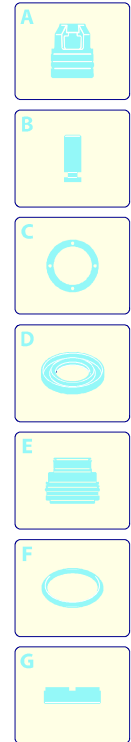
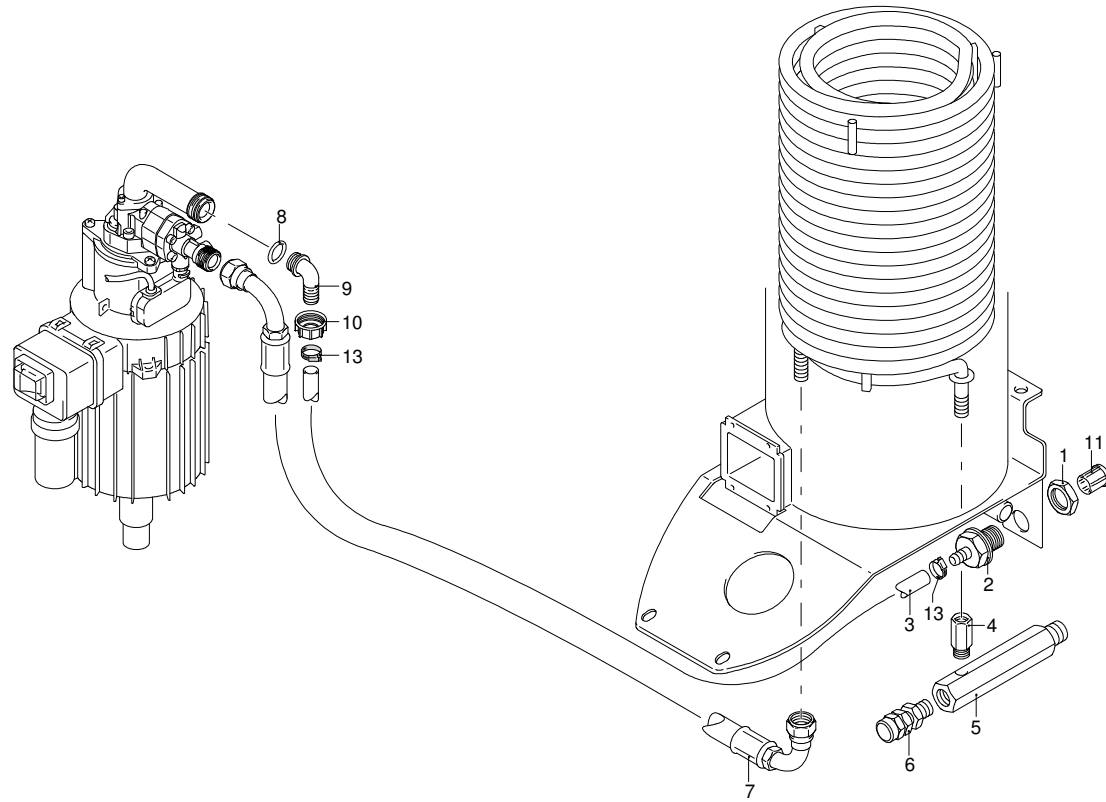



# Modell 1550

Ausführung:

Seriennummer:

Code: **22906**

03/05/2010

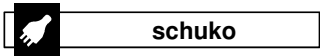
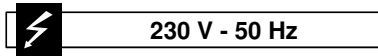

Gültigkeit	Pos.	Code	Bezeichnung	Menge
	1	3162180	Pumpe	1
	2	3162190	Schwingungsdämpfer	2
	3	3162200	Schutzeinrichtung	1
	4	3162220	Verbindungsstück	1
	5	3162320	Rohr	1
	6	3161520	Filter	1
	7	3162330	Rohr	1
	8	3160340	Verbindungsstück	1
	9	3163340	Verbindungsstück	1
	10	3163570	Rohr	1
	11	3162060	Schelle	4

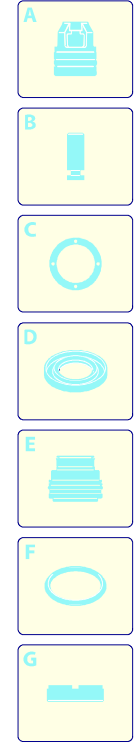
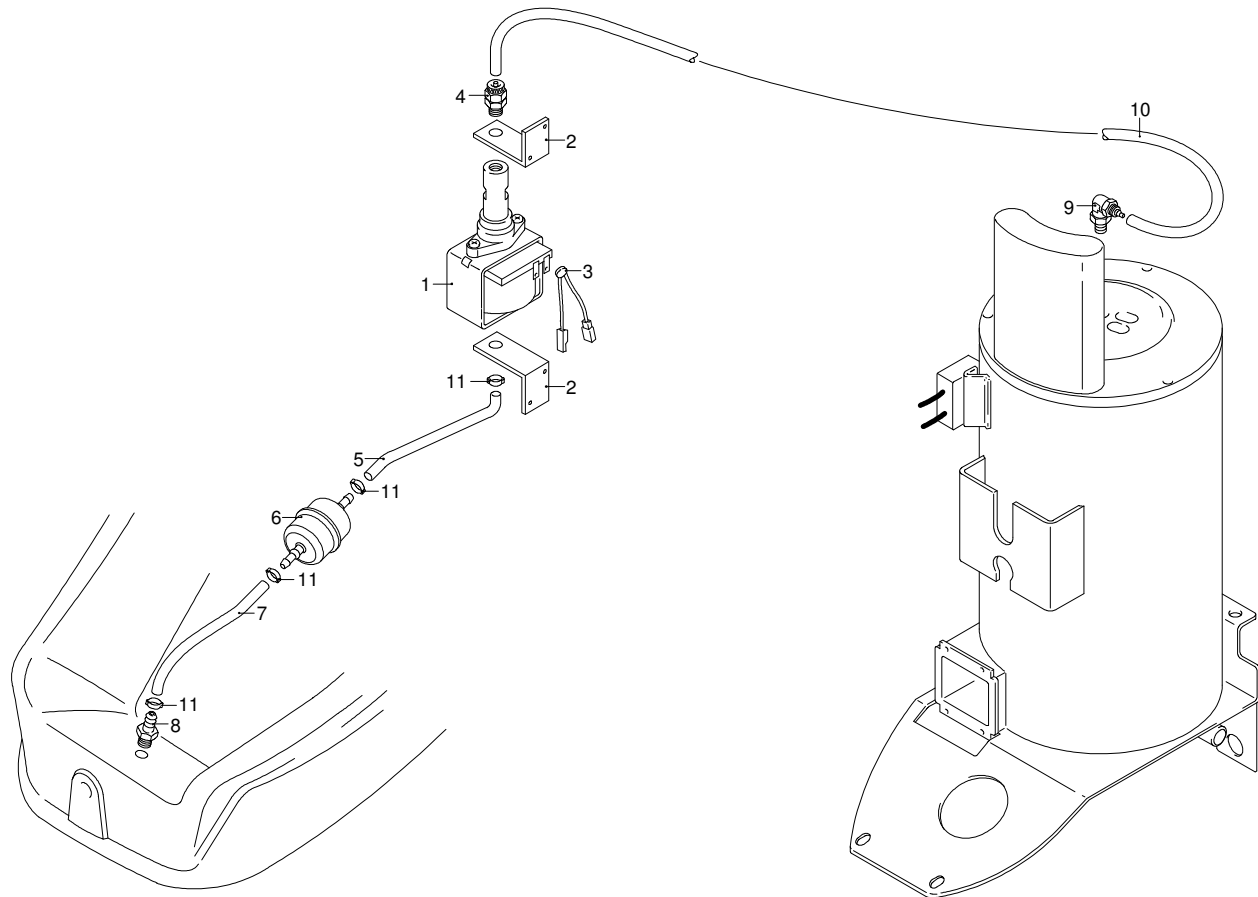

UN\_CE\_0403-CW



# Modell 1550

Ausführung:

Seriennummer:

Code: **22906**

03/05/2010

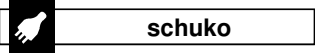
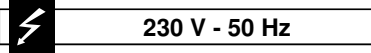

Gültigkeit	Pos.	Code	Bezeichnung	Menge
	1	3161230	Verbindungsstück	1
	2	3163360	Deckel	1
	3	3162240	Kabel Danfoss/Fida	1
	3	3163370	Kabel Brahma	1
	4	3161880	Elektrode	1
	5	3161870	Düsehalter	1
	6	50724	Düse	1
	7	3161560	Halterung	1
	8	3163400	Deckel	1
	9	3163410	Ring	1
	10	3163420	Widerstand	1
	11	3163430	Scheibe	1
	12	3162210	Platte	1
	13	3063220	Trasformator Brahma	1
	13	50717	Trasformator Danfoss/Fida	1
	14	3162090	Kessel	1

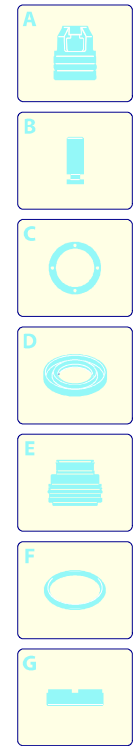
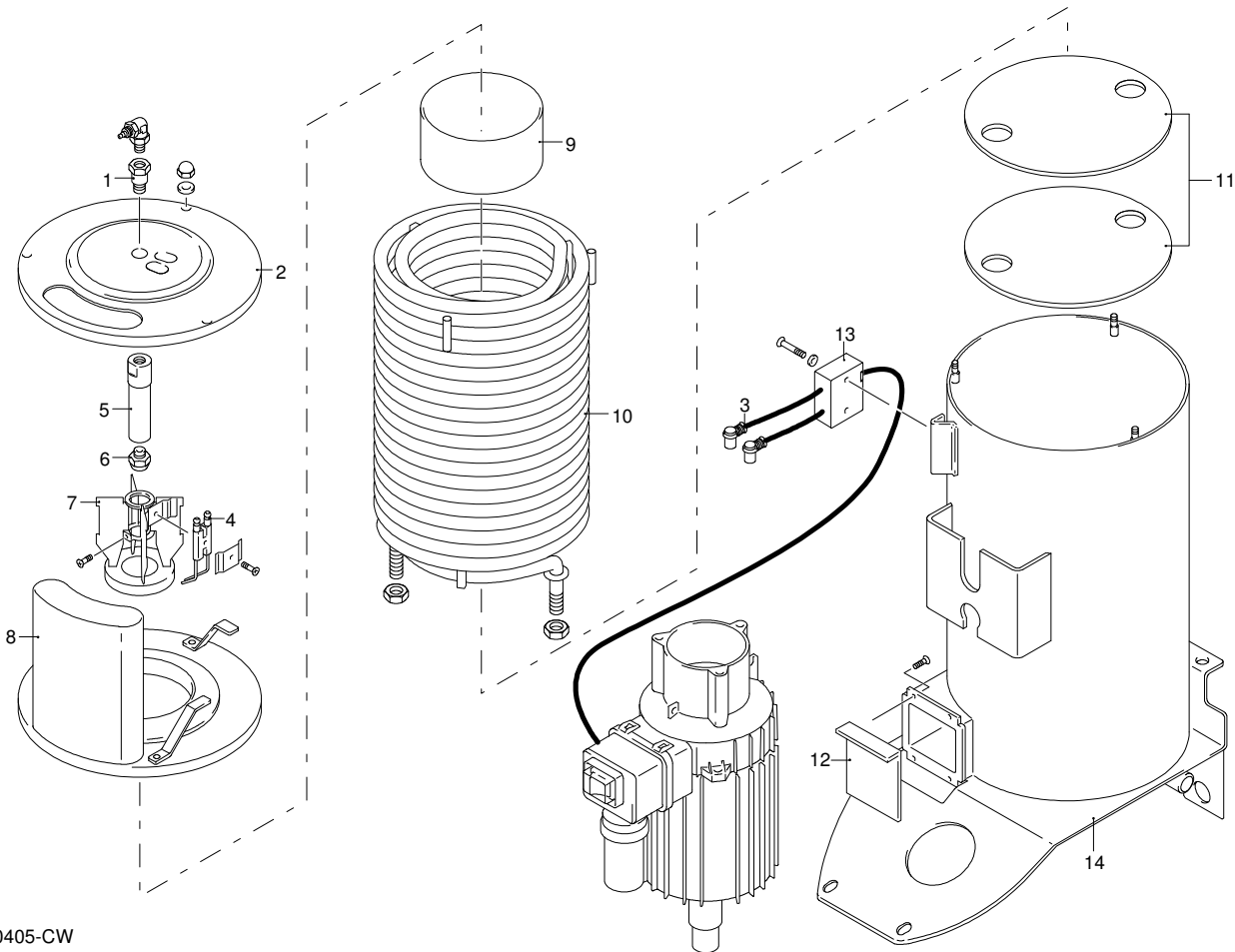

UN\_CE\_0405-CW



# Modell 1550

Ausführung:

Seriennummer:

Code: **22906**

03/05/2010

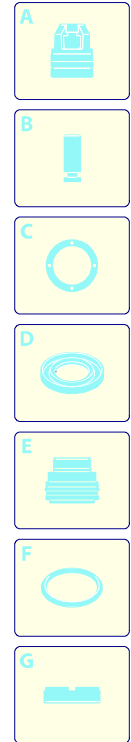
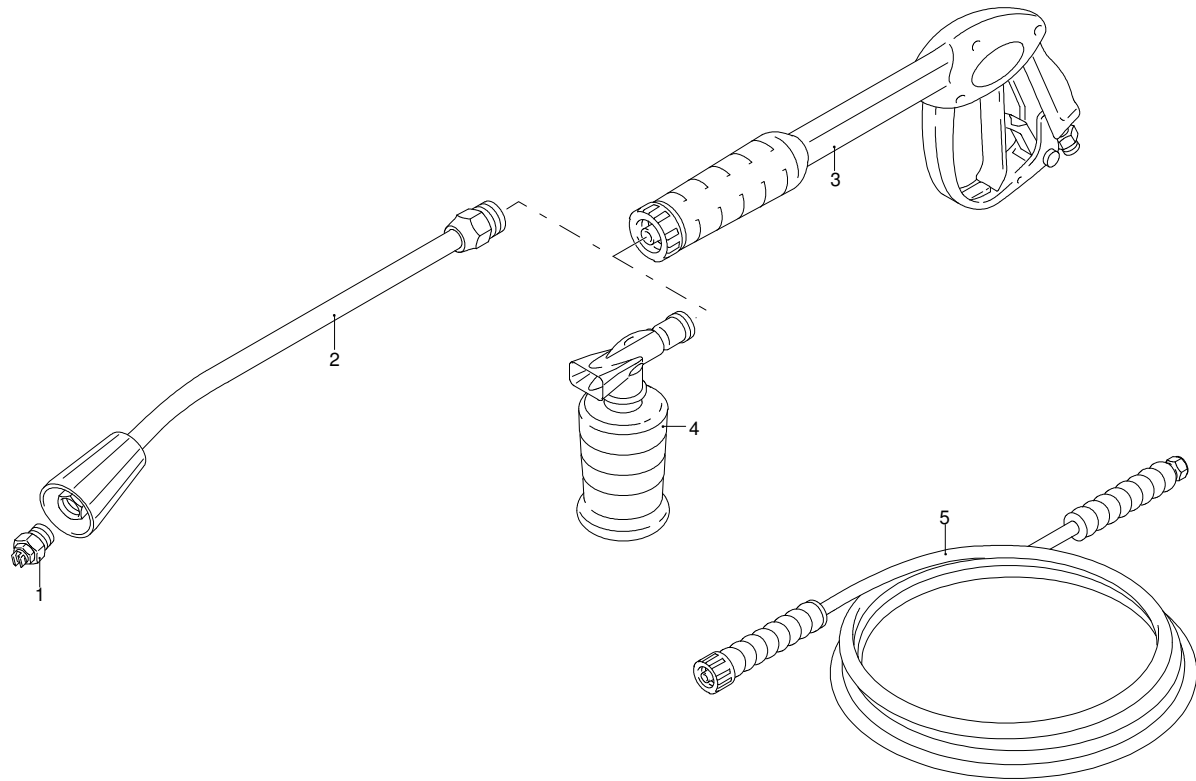
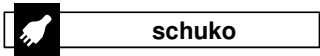
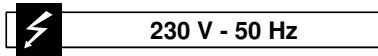

Gültigkeit	Pos.	Code	Bezeichnung	Menge
	1	3729	Düse	1
	2	50690	Lanze	1
	3	40824	Pistole	1
	4	40320	Tank	1
	5	50689	Hochdruckschlauch	1

UN\_CE\_0430-CW