

# XWL-SS VERSION N 1450 rpm

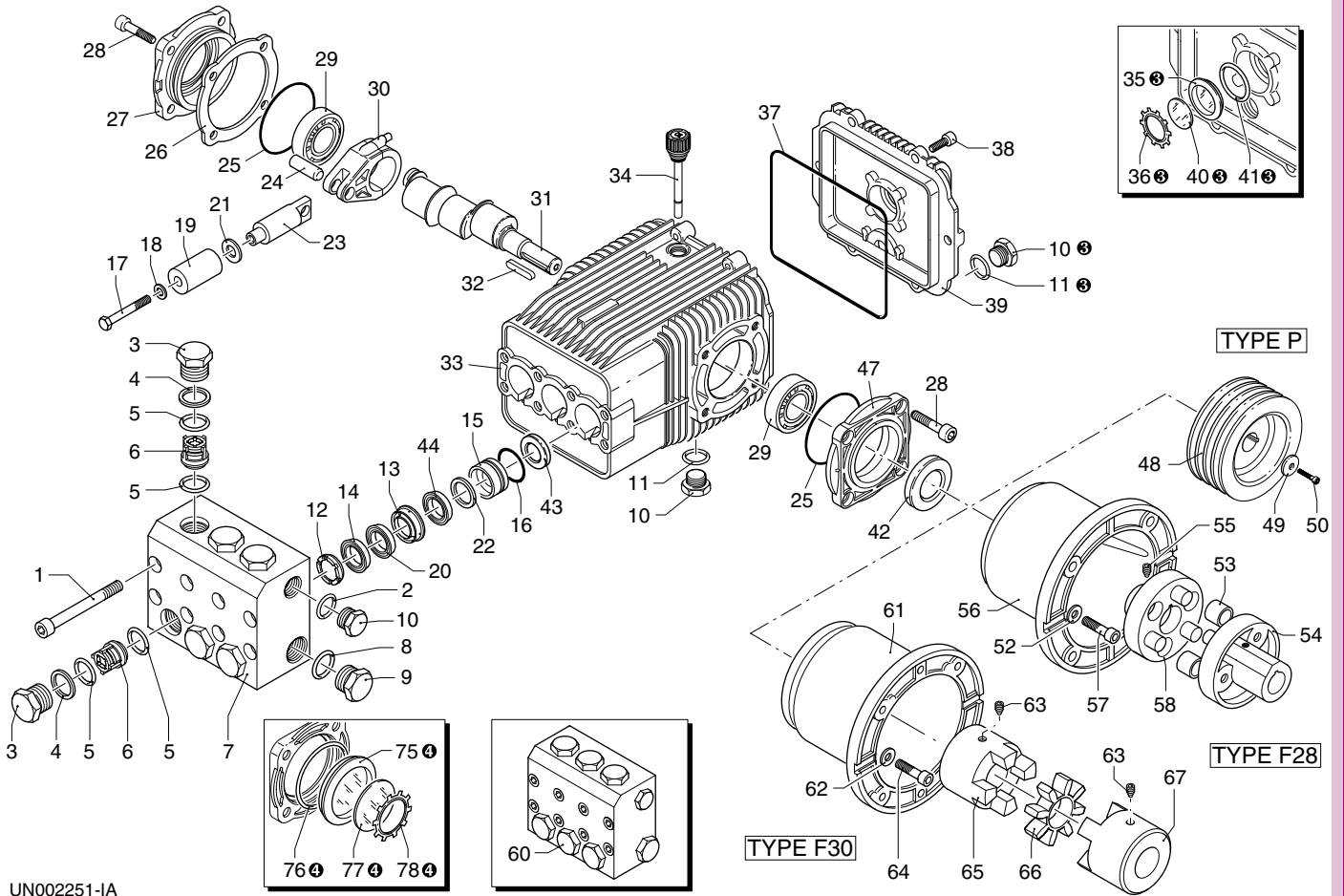

UN002251-IA

## KIT RICAMBI / PART KITS

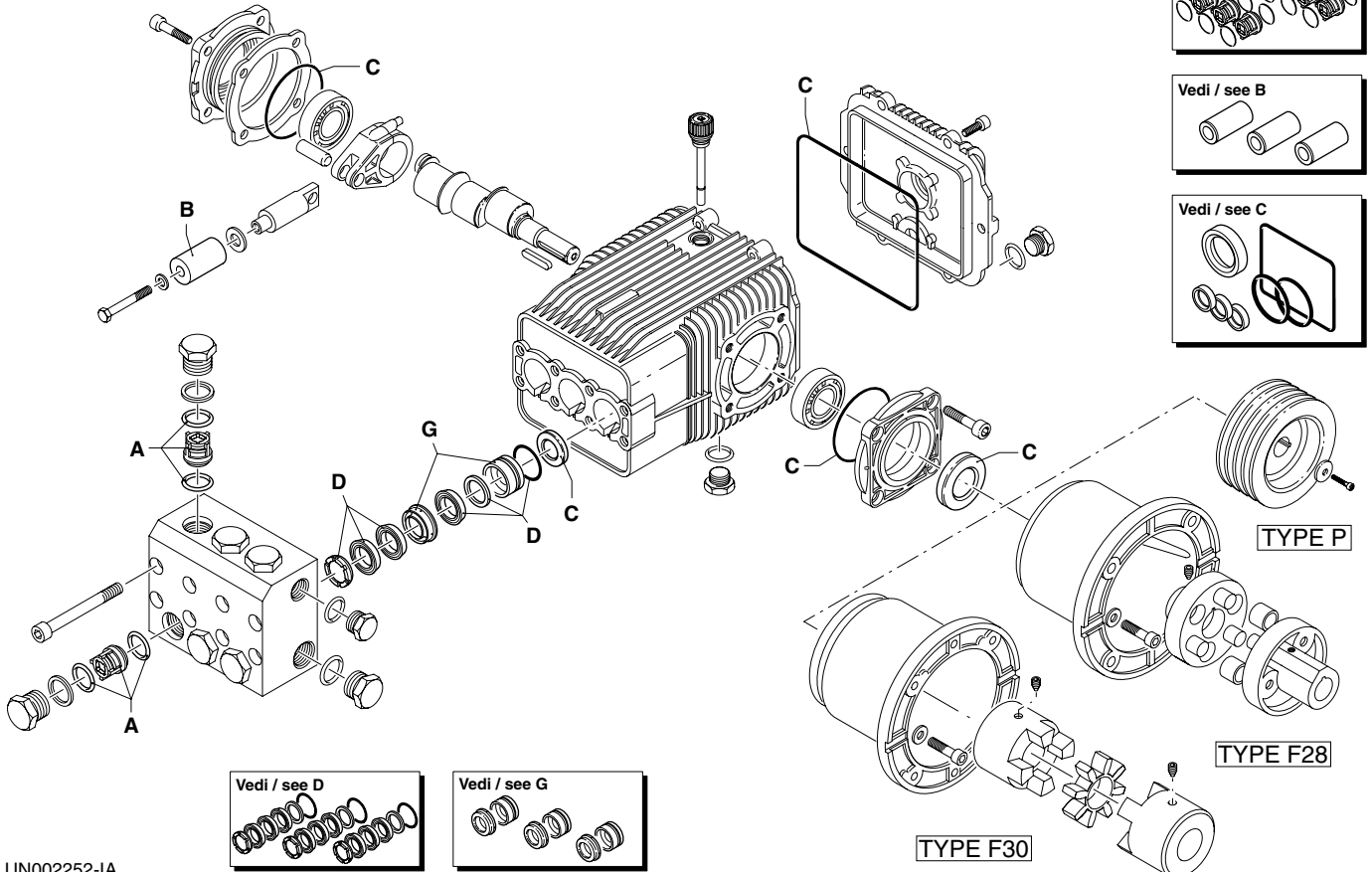

UN002252-IA

# XWL-SS VERSION N

MODELLO - MODEL:  
42.05 42.15



Pos.	Cod. Part n°	Denominazione	Description	Q.tà Q.ty	Note Vedi / See	Pos.	Cod. Part n°	Denominazione	Description	Q.tà Q.ty	Note Vedi / See
1	1941360	Vite TCEI M 10x80	Screw	8		40	1780690	Disco di contrasto	Disc	1	⊗
2	740291	OR Ø 14x1,78	O-Ring	1		41	1140450	OR Ø 20,24x2,62	O-Ring	1	⊗
3	2520030	Tappo	Plug	6		42	820680	Anello tenuta	Seal	1	
4	1940150	Anello	Ring	6		43	1940560	Anello tenuta	Seal	3	
5	1140451	OR Ø 20,24x2,62	O-Ring	12		44	2520361	Guarnizione	Gasket	3	
6	2529050	Valvola completa	Complete valve	6		47	2520320	Supporto aperto	Open bearing sup.	1	
7	2520150	Testa pompa	Pump head	1		48	1940290	Puleggia	Pulley	1	
8	550351	OR Ø 23,81x2,62	O-Ring	1		49	780230	Rondella	Washer	1	
9	2520040	Tappo 3/4" G Inox	Plug	1		50	780060	Vite TCEI M 6x25	Screw	1	
10	2340350	Tappo 3/8" G Inox	Plug	3	⊗	52	390311	Rondella Øi 8,5	Washer	4	
11	740290	OR Ø 14x1,78	O-Ring	2	⊗	53	1321670	Boccola	Bushing	6	
12	1941570	Anello appoggio	Support ring	3		54	1380340	Semigiunto motore	Motor coupling	1	
13	2520200	Guida pist. ant.	Front piston guide	3		55	1380180	Grano M 6x10	Grub screw	2	
14	820631	Guarnizione	Gasket	3		56	1940890	Flangia motori B3/B14	El. motor flange	1	B3/B14
15	2520210	Guida pist. post.	Rear piston guide	3		57	620610	Vite TCEI M 8x30	Screw	4	
16	820491	OR Ø 34,65x1,78	O-Ring	3		58	1940870	Semigiunto pompa	Pump coupling	1	
17	2520260	Vite TE M 6x60	Screw	3		60	2529200	Prem. testa pompa	Pump head assembly	1	
18	2520250	Rosetta	Washer	3		61	1383080	Flangia motori B3/B14	El. motor flange	1	B3/B14
19	2520240	Pistone	Piston	3		62	390311	Rondella Øi 8,5	Washer	4	
20	2520220	Anello antiestrusione	Ring	3		63	1380180	Grano M 6x10	Grub screw	2	
21	2520270	Disco separatore	Spacer	3		64	620610	Vite TCEI M 8x30	Screw	4	
22	2520230	Anello antiestrusione	Ring	3		65	1383100	Semigiunto pompa	Pump coupling	1	
23	2520280	Pistone di guida	Guiding piston	3		66	1940850	Anello elastico	Ring	1	
24	1940060	Spinotto	Piston pin	3		67	1383090	Semigiunto motore	Motor coupling	1	
25	1941380	OR Ø 66,34x2,62	O-Ring	2		75	1941270	Livello olio	Oil indicator	1	⊗
26	1941390	Spessore 0,05 mm	0,05 mm shim	1÷3		76	100410	OR Ø 34,6x2,62	O-Ring	1	⊗
	1941400	Spessore 0,10 mm	0,10 mm shim	1÷3		77	1941260	Disco di contrasto	Disc	1	⊗
	1941410	Spessore 0,19 mm	0,19 mm shim	1÷3		78	1941290	Anello elastico	Snap ring	1	⊗
	1941420	Spessore 0,25 mm	0,25 mm shim	1÷3							
27	2529011	Coperchio lat. compl.	Compl. side cover	1							
28	2340240	Vite TCEI M 8x16	Screw	8							
29	1140410	Cuscinetto	Bearing	2							
30	1940050	Biella	Con-rod	3							
31	1940170	Albero eccentrico	Crank shaft	1							
32	650250	Linguetta	Key	1							
33	2520330	Corpo pompa	Pump housing	1							
34	1140370	Tappo olio	Oil cap	1							
35	1260250	Livello olio	Oil indicator	1	⊗						
36	1260430	Anello elastico	Snap ring	1	⊗						
37	1940410	OR Ø 132x3	O-Ring	1							
38	680560	Vite TCEI M 6x16	Screw	6							
39	2529010	Cop. post. compl.	Complete cover	1							

## KIT RICAMBI - PART KITS

A=KIT 2162 valvole valves		B=KIT 2163 pistoni pistons		C=KIT 2781 tenute olio oil seals		D=KIT 2164 tenute acqua water seals	
Pos.	Q.ty	Pos.	Q.ty	Pos.	Q.ty	Pos.	Q.ty
5	6	19	3	25	2	12	3
6	6			37	1	14	3
				42	1	16	3
				43	3	20	3
						22	3
						35	3

G=KIT 2165 guida pistoni pistons guide							
Pos.	Q.ty	Pos.	Q.ty	Pos.	Q.ty	Pos.	Q.ty
13	3						
15	3						

## SIMBOLOGIA - SYMBOLS

⊗ Compreso nel cod. 2529010 / Part of part n° 2529011

⊗ Compreso nel cod. 2529011 / Part of part n° 2529011